

MIROS OIL SPILL DETECTION AUTOMATIC SURVEILLANCE & TRACKING FOR FAST & EFFICIENT SPILL RECOVERY



DATASHEET

The Miros Oil Spill Detection (OSD) system is a world-leading solution for oil spill surveillance and recovery. This proven technology provides round-the-clock surveillance with automatic spill detection.

Once a spill is detected, Miros OSD can switch its priorities to handle the dynamic and shifting environment of an oil spill recovery operation. The system automatically tracks spills as they develop and drift, facilitating swift and efficient recovery efforts and guiding the optimal positioning of booms, skimmers and dispersant.

KEY FEATURES

- Automatic oil spill detection
- Automatic oil spill tracking
- IR & optical camera integration
- Historical data with playback mode
- High sensitivity & low false alarm rate
- Operational in low visibility, day or night
- AIS targets, wind, current and wave data
- Access data locally & remotely

ESSENTIAL FOR

- Round-the-clock oil spill surveillance
- Fast and efficient recovery of oil spills
- Efficient deployment of boom/skimbers
- Post-incident analysis
- Spatial positioning & thickness estimation

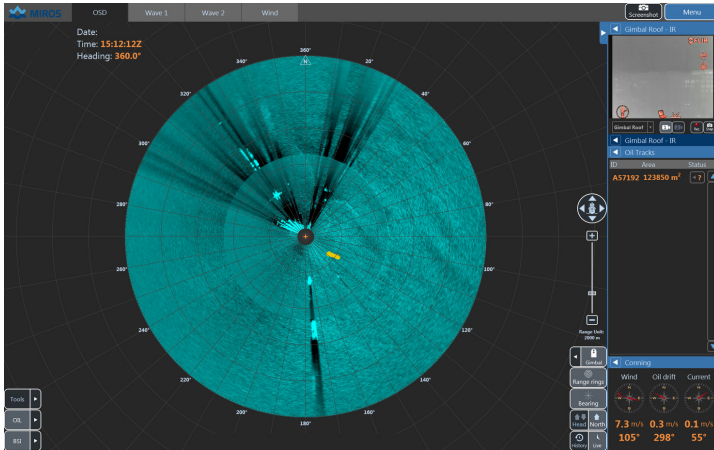

The graphical user interface shows present and historical oil spill detections. Wind and ocean current data, as well as oil drift direction and speed, are also displayed. The addition of wave information is optional.

Miros OSD receives data input from X-band marine radars, optional IR/optical cameras, and existing wind, GPS, gyro and AIS sensors.

Positions and shapes of radar detections are overlaid by AIS targets and drift buoys.

The optional addition of IR and optical cameras can aid operators in the verification of oil spill detections, the identification of the thickest parts of the spill, and estimation of spill thickness and volume.

Historic radar imagery can be played back providing a clear insight into an oil spill's development as well as serving as a recording of the contingency efforts undertaken.

Alarms are managed with configurable thresholds, operator acknowledgement and alarm history.

SPECIFICATIONS

Detection Mode

Surveillance Mode:
Recovery Mode:

Characteristic

Low false alarm probability
High detection probability

Detection range by radar (typical range, depending on antenna height and local wind conditions):

Radar Pulse Mode

Short Pulse:
Medium Pulse::

Pulse Length

50 - 80 ns
250 - 300 ns

Range_{MAX}

2 - 4 km
4 - 7 km

IR camera range (typical clear weather range depends on camera height)

Target

Oil:
Detect human size target:
Detect 30ft vessel:

Range_{MAX}

0,9 - 6,0 km
1,0 km
3,7 km

Tracking

Radar:
Camera:

Multiple oil spill targets
Multiple oil spill targets, AIS targets and drift buoys

Input Interfaces

Gyro Heading: NMEA-0183
GPS Position, Time: NMEA-0183
Wind: NMEA-0183
AIS: NMEA-0183

X-Band Radar Interface

Ant. Beam Width: 1.3° or less (6 feet or more)
Ant. Rot. Speed: > 15 RPM
Ant. Mount. Height: > 15 m above sea level
Pulse Mode: Short pulse (50 - 80 ns) or medium pulse (250 - 300 ns)
Pulse Rep. Frequency: 1000 Hz or higher
Output Power: 10 kW or more
Radar Signals: Raw video, sync, heading marker and azimuth
Antenna Polarisation: Vertical or horizontal

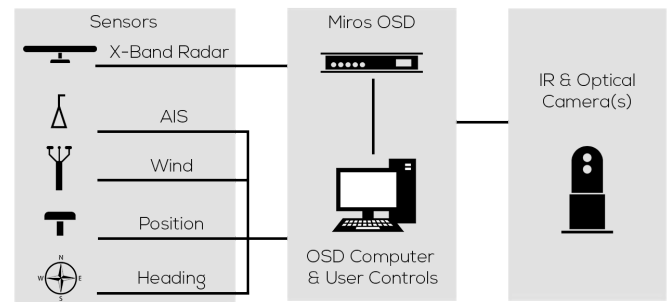

Output Interfaces

Data: Ethernet, FTP on TCP/IP
Alarm: Visual, sound

Environmental specifications outdoor equipment

Temperature: -30°C to +50°C
Humidity: 0 - 100 % RH condensing
IP (Outdoor Equipment): 56

Electrical Data

Supply Voltage: 100-240 VAC 50-60 Hz
Power Consumption: Nom: 250 W, max 300 W (basic system)

Specifications are subject to change without prior notice.